

OPERATING INSTRUCTIONS RH-50

- Use only non-foaming, non-chlorinated detergents suitable for automatic dishwashers such as Rhima's range of detergents.
- Ensure clear hose is inserted into the detergent bottle and green hose is inserted into rinse additive bottle.
- For best performance connect machine to HOT water.
- If pre-soaking do not use regular dishwashing liquid as significant foaming may result during the wash cycle.

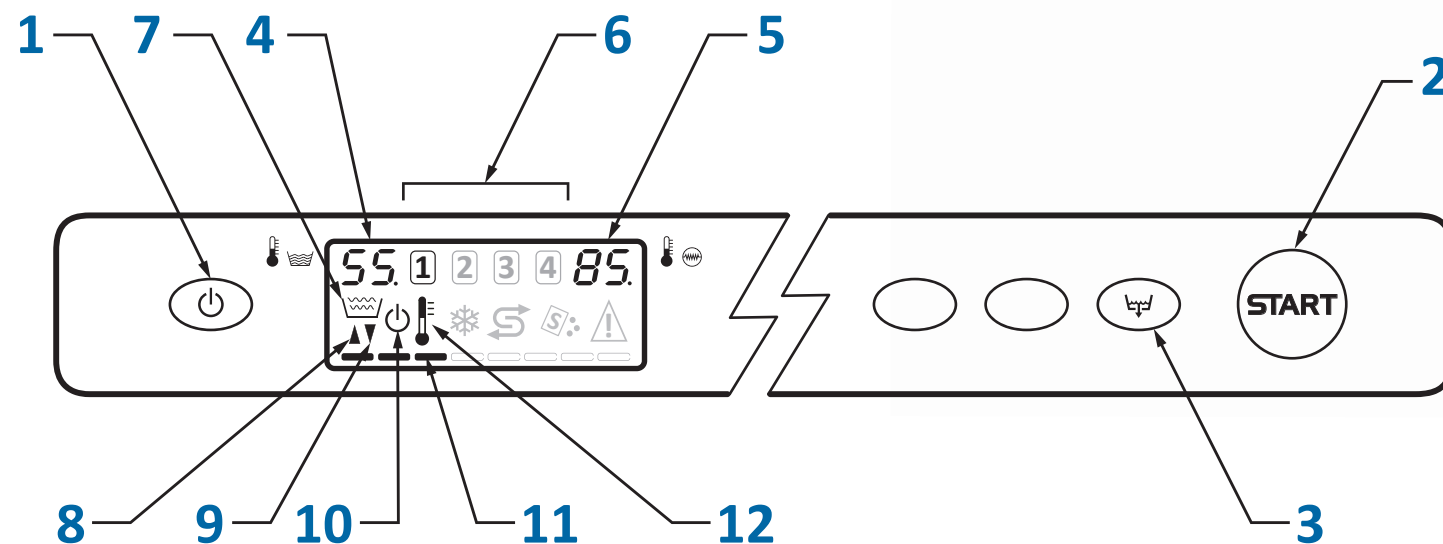

- (1) ON/OFF/STAND-BY
- (2) Push button to start cycle
- (3) Push to drain (optional)
- (4) Tank temperature display
- (5) Boiler temperature display
- (6) Cycle indicator
- (7) Tank filling/draining indicator
- (8) Filling indicator
- (9) Draining indicator
- (10) STAND-BY indicator
- (11) Cycle scroll bar
- (12) Set temperature indicator

Operating the machine

INITIAL FILL AND HEATING

1. Close the door and press the ON/OFF switch (1).
2. Machine is ready for use when the TEMPERATURE REACHED INDICATOR (12) illuminates.



3. The WASH TANK (4) and BOILER (5) temperature indicators display the wash tank and boiler temperatures respectively.

DISHWASHER OPERATION

1. Load the rack with plates/cups/glasses ensuring items do not overlap.
2. Close the door and start the wash cycle by pushing and holding the START button (2) for 1 second.
Note: The 4 wash programs (6) can be scrolled through by pressing and holding the START button (2). When the desired program is selected release the button.
3. The wash cycle will begin, and the progress will be indicated on the CYCLE SCROLL BAR (11).
4. When cycle is finished the START button (2) will flash.
5. The washed items will air-dry within a few minutes of being removed from the dishwasher. The use of rinse additive will improve drying times.

Draining the machine

1. To maintain good wash results, the dishwasher should be drained and refilled every 2-4 hours depending on frequency of use and level of soil/residue on items being washed. At the end of the day, the dishwasher should be drained, switched off and the door left open to ventilate.
2. Leave the machine switched on. Open the door and remove the OVERFLOW PIPE (A). Fig. 1

DO NOT REMOVE THE GREY PLASTIC FILTERS (B) FIG. 1. THESE PREVENT SCRAPS OF FOOD GOING DOWN INTO THE DRAIN PUMP.

Blocked drain pumps are not covered by warranty.

3. Press and hold the DRAIN PUMP button (3) for 1 second.
4. The dishwasher will automatically empty the wash tank and enter standby mode.
5. Remove grey plastic PUMP FILTER (B) Fig. 1 and wash under running water and refit the filter and OVERFLOW PIPE (A).

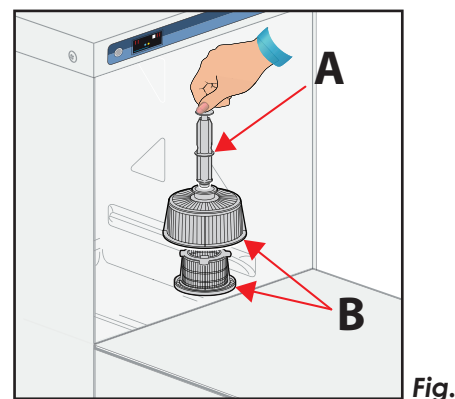

Fig.1

Self Clean Cycle & Regular Maintenance

SELF CLEAN CYCLE

1. To run the SELF-CLEAN cycle, press and hold the START button (2) for 5 seconds and the SELF-CLEAN cycle will start automatically.
2. On completion, drain the machine by following machine draining instructions.

REGULAR MAINTENANCE

1. Remove the fixing screw (D) Fig. 2 to remove the wash/rinse arms. Check that the nozzles (E) Fig. 2 are not blocked with food waste. The nozzles can be removed for cleaning if required.
2. Reinstall the wash/rinse arms using fixing screw (D) Fig. 2.

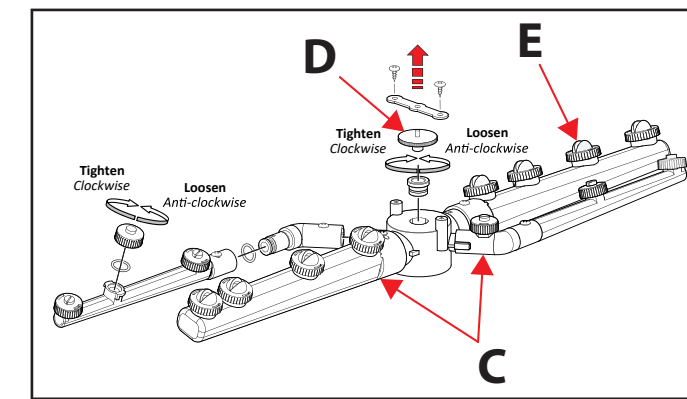

Fig.2