

Operator's Manual



RG 9 & RG 9 HR Washer



INSTRUCTION MANUAL FOR DISHWASHERS



It is important to keep this instruction manual near the appliance for future consultation.

If the appliance is sold or transferred to another user, make sure this manual remains with the appliance so that the new owner is informed about the warnings and operation of the appliance. These instructions are given for safety reasons and they must be read carefully before installing or using the appliance.

GENERAL INSTRUCTIONS

- The appliance must be connected to water and electrical supplies by qualified tradespersons only and according to local regulations.
- The appliance must be used by adults only. Do not let children play with, or operate this machine.
- Only persons trained to use this dishwasher are permitted to operate it.
- This appliance has been designed to wash food preparation and eating utensils. It has NOT been designed to wash objects soiled with petrol, paint, remnants of steel or iron, corrosive chemical products such as acids, alkalis, or solvents or any item that cannot be immersed in water.
- Do not open the appliance door or lift hood while the appliance is operating. The appliance has a safety device which stops operation if the door or hood is accidentally opened.
- After using the appliance, isolate the electric and water supply.
- Do not attempt to repair the appliance. Repairs made by unqualified persons may cause further damage and will void warranty.
- Repairs and servicing of this appliance must be carried out by Rhima personnel only.

IMPORTANT CUSTOMER INFORMATION

- To request a service, detergents or rinse additive contact your local Rhima Service centre below:

Australia: **1300 347 944**

New Zealand: **0800 902 054**

Singapore: **+65 9107 8943**

ELECTRICAL INSTALLATION

This appliance is intended to be connected to a **3 x 20.3 Amps** electrical supply and **must be earthed**.

PLUMBING INSTALLATION

The Australian installation shall be in accordance with The Plumbing Code of Australia (PCA).

This appliance should be connected to a hot water supply (Max 65°C) for in accordance with Australian Standard AS/NZS 3500.1. for optimum performance.

The water supply pressure should be a minimum 200 kPa at all times and flow rate should be at least 10 litres per minute. A static pressure higher than 600 kPa (73.5 psi) requires a pressure reducing valve upstream of the supply line. If water pressure is below 150 kPa, the use of a rinse booster pump is recommended.

This appliance is designed to drain to a tundish. Waste connection to a spigot is not recommended and may cause draining issues.

The drainpipe should withstand 70°C (158°F) in continuous duty conditions.

The grey water drain hose must have a fixed watertight seal above the tundish in accordance with the Australian Standard AS/NZS 3500.2.

A DIAGRAM SHOWING THE CORRECT METHOD OF WASTE INSTALLATION IN ACCORDANCE WITH THE AUSTRALIAN STANDARD AS/NZS 3500.2 IS BELOW



INSTALLATION TO BE IN ACCORDANCE WITH AUSTRALIAN STANDARD AS/NZS 3500.2

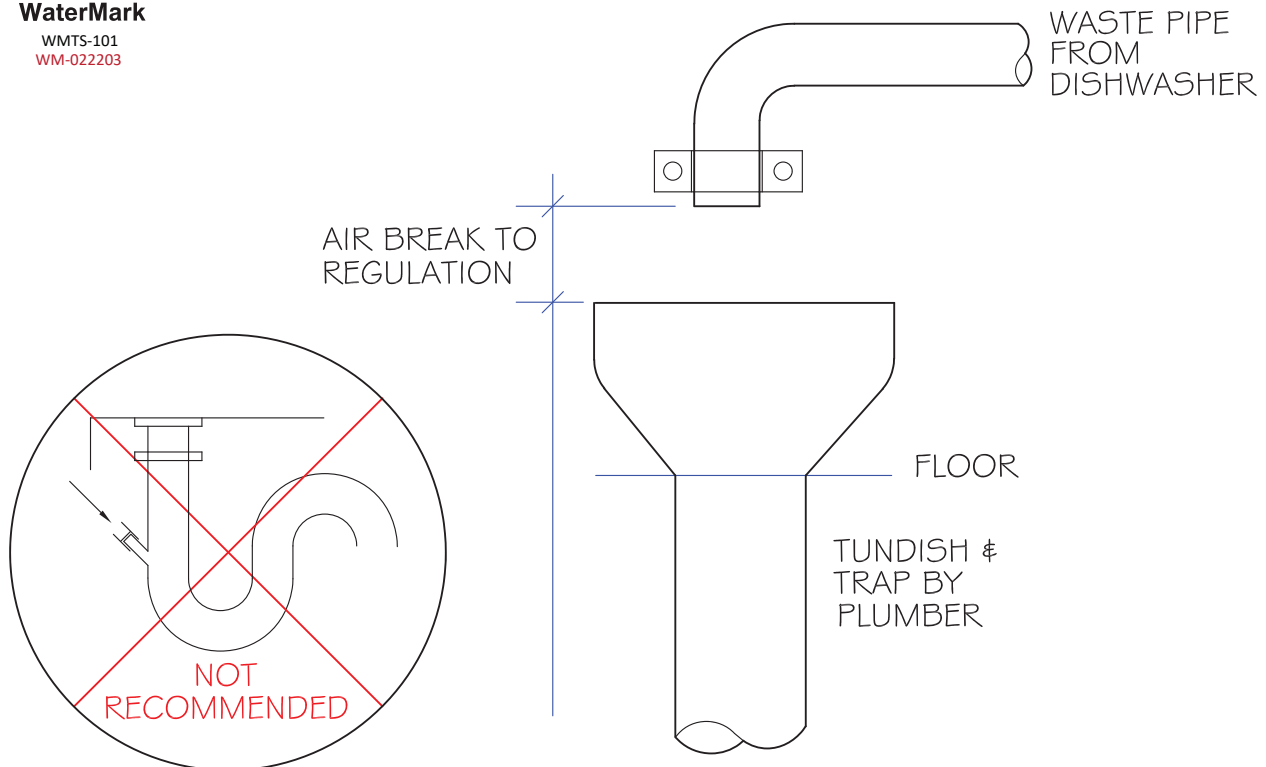

GRAVITY WASTE

CONTROL PANEL AND SYMBOLS

The present specifications are intended as a functional description of the display.
To simplify function description the control panel display with function control keys is represented here-below.

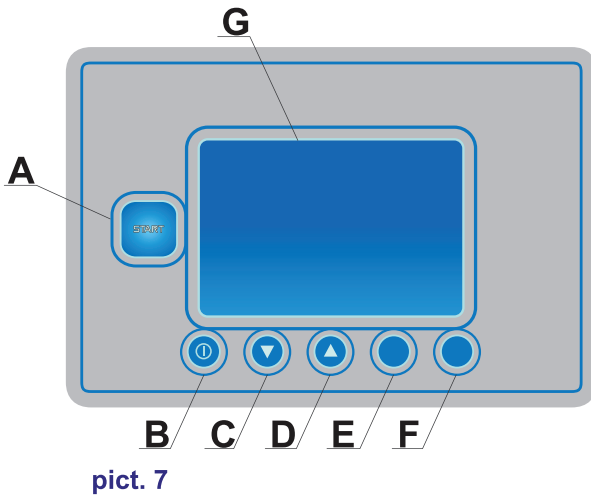

Function keys during normal operation

A: Cycle Start/Stop.

Multi-chromatic button:

Firm red light: machine filling/heating;

Flashing red light: alarm signal (check the code on the alarm chart chap. **DETECTION AND DISPLAY OF ALARMS AND FAULTS**);

Green light: machine ready. Select cycle;

Firm blue light: machine in operation;

Flashing blue light: machine in stand-by (boiler drainage).

B: Machine power **ON/OFF** (in stand-by only).

C: Cycle Selection;

D: Cycle Selection;

E: Cut out;

F: Cut out;

G: LCD Display

FEATURES

General features

The control unit managed by a microprocessor manages the following:

- boiler water load
- tank water load
- boiler temperature setting
- tank temperature setting
- function cycles
- fault detection and display.

OPERATION

General operation

To be ready to operate, the machine needs 3 connections:

- Electrical
- Water supply
- Water drain.

The machine consists in a wash chamber, inside which there is:

- A rack support, connected to a clutch equipped gear, where the rack is placed to rotate during the wash cycle.
- Two wash arms where water and granules flow from.
- A rinse arm connected to a booster pump, fed by the boiler, guaranteeing constant temperature rinse ("Plus" system).
- A filter located under the chimney to prevent particles from rising and getting stuck in the fan located at the end of the chimney.

A double tank is made under the wash chamber, containing water only in one half and water mixed with granules in the other half. The part containing water only shall always be covered by blind covers to avoid granules penetration.

The part containing the granules in water mixture shall always be covered by the perforated filters. To recover the granules, the collection strainer with special side compensatory chutes (see par. **Granule cleaning and collection**).

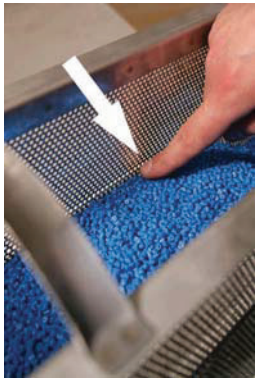

Photo 1

Machine preparation

- Prepare the right amount of granules by filling the strainer to the indicated level (see photo 1).
- Pour the contents into the right-hand side of the tank.
- Place the overflow pipe in the dedicated seat, at the tank bottom (see photo 2).
- Insert the two cover-filters above the water-only area (left side of the tank) and the two perforated filters above the granule area (right-side of the tank).
- The filters shall be cleaned every 15-20 cycles and whenever necessary. **Do not use the machine without filters.**
- Make sure that the wash and rinse arms are properly and firmly placed.
- Make sure that the rack support is inserted properly.
- If the machine is equipped with a detergent dispenser, insert the transparent hose into the detergent canister.
- Insert the special green rinse-aid chemical container and check that the quantity available is sufficient for the workload of the day.
- Shut, gently, the door.
- Open the water valve (or the 2 water valves if the machine is separately connected to cold and hot water supply), activate the main wall switch and proceed with turning on the machine by pressing the push-button **B (ON/OFF)** - see pict. 7). The display will light, indicating the software update and the **A (Start)** button will be in white light. After a few seconds, the display and the **A (Start)** button will become red, indicating the refilling phase. Should the machines be equipped with the WRAS certified Break Tank, the tank filling phase is extended.
- After water-filling, the machine will automatically activate the heating stage. The **A (Start)** button will be lightened in red and the display will indicate the heating phase.
- Till the set temperatures in the boiler and in the wash tank will not be reached, it will not be possible

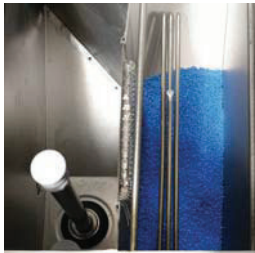

Photo 2

- to start any wash cycle. The machine will be ready to wash only when the **A (Start)** button and the display will be green.
- Insert the rack with the various objects to wash (see par. **Rack preparation**) and shut, gently, the door.
- Before beginning the wash cycle, insert the proper detergent into the tank (if the machine is not equipped with an automatic dispenser).
- Select the wash cycle by the **C/D** (see pict. 7) buttons. The display will show the selected cycle.
- Start the cycle by pressing the push-button **A (Start)** - see pict. 7). The actual cycle start will be signaled by the change in color of the display and the **A (Start)** button, that will switch from blue to green light. At the end of the cycle, the **A (Start)** button will flash (green/blue) and the display will show **CYCLE ENDED**.
- The machine is ready for a new wash cycle.
- It is recommended to replace the tank water with new water at least after 30 wash cycles or 2-3 times a day.

N.B.: The machine does not accept other cycles until the door is opened or the **A** (see pict. 7) is pressed twice. The pre-adjusted factory settings are not modifiable. The settings are 4 - 6 - 8 - 10 - 12 - 15 minutes with water only and 4 - 6 - 8 - 10 - 12 - 15 minutes with granules.

Detergent use



The detergent shall be the NO FOAM type, suitable for industrial dishwashers. The use of good quality liquid detergents is recommended.

WARNING: for washing aluminium-ware, please use specific detergents.

The detergent shall be placed in the tank. Follow manufacturer recommendations for dosage. The machine can be ordered with an adjustable automatic detergent dispenser.

Lack or poor quality of detergent, in this machine will cause bad wash results and clogging.

Rinse aid use



The machine has a standard rinse aid dispenser. The machine automatically sucks the product.

The rinse-aid chemical, shall be suitable for professional glass and dishwashers. It is advisable to rely on specialized retailers in the sector.

Rack preparation

In order to obtain the best performance of the machine and optimise its running costs, we do recommend to load the machine properly, also balancing weights as much as possible on the whole surface.

Note: All objects are to be inserted in the rack "dirty face out". Having a machine with lateral wash and rinse arms, an object must not be placed in front of another or else the one behind will not be washed.



photo 3



photo 4

Equipment for machine with 735 mm Ø rack

The machine is equipped with:

- a) A round rack. On the round rack, one can put: : 6 GN 1/1 or 6 GN 2/3 or 6 GN 1/2 or 12 GN 1/3 (photo 5).
On the round rack one can put also: 2 GN 2/1 (photo 6) or 1 GN 2/1 and 3 GN 1/1 (photo 7).



photo 5



photo 6



photo 7

- b) A tray-stand for service trays (see photo 8). The tray stand allows the washing of 10 trays max 40mm depth. While using this stand, other objects may not be introduced, as they would interfere with the wash result.
This stand is not recommended for oven trays, but for service-trays with light dirt only.



photo 8

- c) Four stands for cooking trays. (see photo 9). The four tray-stands allow the washing of bakery trays of various depths. It is also possible to prepare a rack mixing the above components (photo 10 - 11 - 12).



photo 9



photo 10



photo 11



photo 12

Equipment for machine with 850 mm Ø rack

The machine is equipped with:

- a) A round rack and 4 vertical supports. On the round rack by inserting the supports, one can put: 8 GN 1/1, or 4 GN 2/1, or 4 GN 1/1 and 2 GN 2/1, or 1 GN 2/1 and 6 GN 1/1, or 3 GN 2/1 and 2 GN 1/1 (see photo 13 - 14).



photo 13



photo 14

b) 3 supports for 800x600 mm trays. Each tray support allows the wash of one 800x600 tray, up to three pieces. It is also possible to prepare a rack mixing the above components (photo 15 - 16).



photo 15

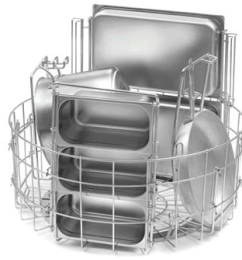

photo 16

Mutual Equipment

a) Rack/utensil pyramidal insert. The pyramidal stand fixed to the centre of the rack supports the cutlery racks as well as pots without handles (photo 17).



photo 17

b) Utensil rack

c) Pan stand. The pan rack stand allows washing pans of any size with handles. The upper telescopic part offers easy insertion and removal (photo 18 - 19).



photo 18



photo 19

d) Pot stand. The pot stand allows washing any pot with handles (photo 20 - 21).



photo 20



photo 21

e) 1 support for containers GN 1/1 - 2/3 - 1/3 - 1/2. This support allows the wash of 1 container 1/1, or 1 container 2/3 and 1 container 1/3, or 3 container 1/3, or 2 container 1/2 (photo 22 - 23 - 24).



photo 22

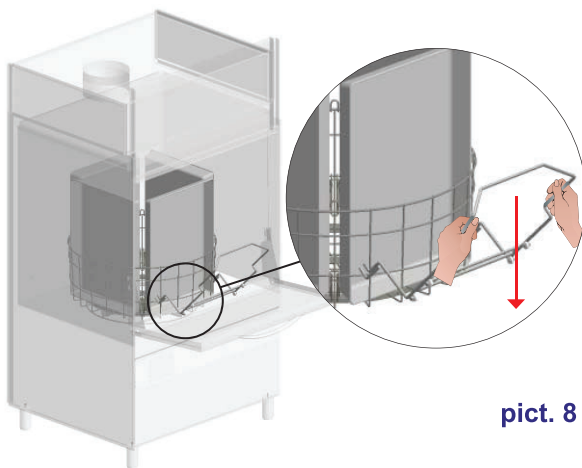

photo 23

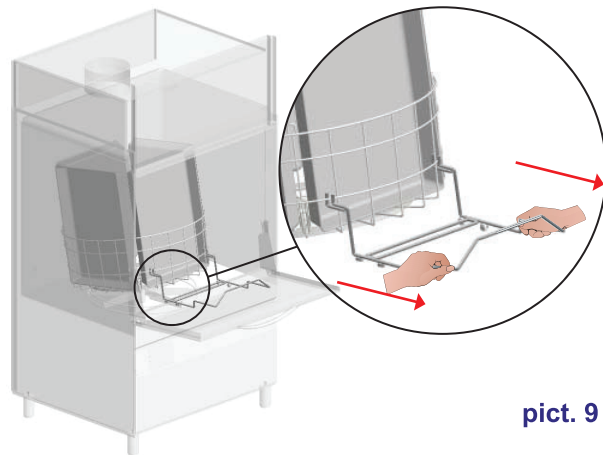

photo 24

f) A rack lifter. Hook the rack with the lifter as shown in pict. 8. Press the lifter downwards, until the wheels touch the machine's door, and the rack rises for a few centimetres (see pict. 9).



pict. 8



pict. 9

Maintaining the lowered position, pull the lifter, hooked to the rack, outwards until the lifter wheels reach the end of the door. Now it is easy to unload the objects contained in the rack.

Final check

When the message **Cycle ended** appears on the display, the machine has finished the cycle and it is possible to open the door and remove the rack.

ALWAYS CHECK WASHING RESULTS. MAKE SURE THAT NO GRANULES ARE ON THE WASHED OBJECTS. IF SO, REMOVE THEM.

It is mandatory to repeat the washing cycle if at the end of the cycle the crockery are not well clean or if there are washing residues (kitchenware, pots, etc. with liquid inside).

Granule cleaning and collection

To collect the granules in the tank:

- Remove the two filters.



photo 25

- Replace with the strainer and two lateral compensation chutes.



photo 26



photo 27



photo 28

Once this operation is complete, simply select cycle 1 granule mode and with the door shut press the push-button **A (Start)**. One the cycle is finished, the granules shall be found in the collection strainer. To clean, simply place the strainer in a sink and wash from above.

On this occasion, check granule consistency and quantity (see photo 1).

If they are too small and spherical, replace; if they are too few, add to level.

Excessive amount or lack of granule can result in unsatisfactory results, when using the granule mode.

The weight of the granules collection strainer, when fully loaded, may vary from 5 to 9 kg, depending on machine's version.

H.A.C.C.P. and hygiene regulations

- The machine is equipped with temperature displays that indicate boiler and tank temperature. It is recommended to warm the machine up, until the set temperature is reached.
- Remove carefully all solids from the objects to be washed, to avoid obstruction of filters, nozzles and piping.
- Drain the wash tank and clean the filters at least 3 times a day.
- Check if the detergent and rinse-aid dosage are correct (as recommended by the manufacturer). In the morning, before starting the machine, check that the quantity of chemicals in the canisters is enough for daily supply.
- Keep your working tables clean.
- Extract the rack with clean hands or gloves to avoid finger marks.
- Do not dry or polish the washed objects with cloths, brushes or rags that are not sterile

Booster pump/rinse

After a period of inactivity of the machine, the rinse booster pump might get blocked, due to oxidation. Should this problem occur the alarm **B4 - Failure in rinsing** - (see par. **Alarms**) will appear. Call a Service Technician to unblock the pump.

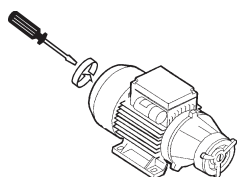

pict. 10

Thermo-stop function

This function is always active at the end of each wash-cycle. If the boiler did not reach the right rinse temperature, the wash cycle will continue till the correct rinse water temperature is reached.

Conditions that inhibit the washing cycle start

The washing cycle is annulled and brought to stop position under the following conditions:

- a fault is detected
- the **B (ON/OFF)** - see pict. 7) push-button is held for more than 2 seconds.

Conditions that inhibit the washing cycle start

The cycle is inhibited under the following conditions:

- the door is open: in this situation the display shall read **Door open** for 4 seconds
- water is lacking; in this situation the display shall read **Loading water in the wash-tank** for 4 seconds
- when the alarm sounds
- during tank loading and during the boiler and tank heating.



ECOLOGICAL ASPECTS

Recommendations for optimal use of energy, water and additives

Use the machine fully loaded when possible: This shall prevent detergent, rinse aid, water and energy consumption waste.

Detergent and rinse-aids: Use detergents and rinse-aid chemicals with high biodegradability, to best respect the environment. Verify proper dosage in relation to water hardness at least three times a year. Excess product pollutes rivers and seas while an insufficient dose results in unsatisfactory dish washing and/or hygiene.

Boiler and Wash-Tank temperatures: The boiler and tank temperatures are set by the manufacturer in order to obtain the best washing results with detergents on the market. The temperatures can be reset by the installer in relation to your detergent.

Pre-washing: Carefully pre-wash with a moderate amount of water at room temperature to facilitate the removal of animal fats. To remove encrusted materials warm water soaking is recommended.

Note: Wash objects as soon as possible to avoid deposits from drying and compromise effective washing. For effective washing routine dishwasher cleaning and maintenance is advised (see chap. **MAINTENANCE**).



Disregarding the points listed above and of any the information contained in this manual can cause energy, water and detergent waste with a subsequent increase in running costs and/or performance reduction.



MAINTENANCE

WARNING: The machine is not protected against pressurized water jets. Do not use pressure cleaning system against the machine.

It is recommended to contact seller for cleaning instructions, in order to have detailed indications on methods and products for the correct periodical machine sanitation.

Do not use bleach or chlorine based detergents.

Routine maintenance

Daily cleaning is needed to ensure that the machine runs perfectly. The following shall be carried out:

- Granules recovery (see par. **Granule cleaning and collection**).
- Turn the machine in stand-by mode, by pressing the push-button **B** of the control panel (see pict. 9).
- **Switch off the main switch installed on the wall.**
- Drain the water by removing the overflow pipe.
- Remove the filters and chutes and clean with a brush and a water shower.



pict. 11

- Remove the wash and rinse pipes. Carefully clean the nozzles under running water.
- Clean the tank and wash chamber very carefully, using a water shower.

Carefully remove dirt and clogging from the vertical screen-wall separating the two wash tanks. Wash well in the conduct of the washing circuit, injecting water under pressure in the clutch of the wash arms.

- Reassemble the rinse nozzles as originally assembled.
- Reassemble the parts and reposition the wash and rinse pipes firmly in place.
- It is recommended to leave the machine door open at the end of the day.



PAY ATTENTION TO WASH PIPES ASSEMBLY (see pict. 11):

A => FRONT WASH PIPES (code 96617)

B => REAR WASH PIPES (code 96616)



Note: It is recommended to change the water in the wash-tank at least every 30 wash cycles or 2-3 times a day. Do not use metal-wool for cleaning and/or corrosive products that will damage the machine



Extraordinary maintenance

Once or twice a year have the machine inspected by a qualified technician, in order to:

- Clean the solenoid-valve(s) filters
- Remove scale from the heating elements
- Control the status of the seals
- Control for components integrity and/or consumption
- Control the dispenser(s) efficiency
- A qualified electrician, should check all electric connections inside the machine, at least once a year.

Alarms

Fault signals are displayed with the message followed by the fault code and by a short description of the fault.

FAULT CODE	TYPE OF FAULT	SOLUTION
B1	BOILER NOT FILLED	Open the water supply tap and verify a proper water supply flow. Contact the Rhima Service Department.
B2	BOILER SENSOR FAILURE	Contact the Rhima Service Department.
B3	BOILER NOT HEATED	Contact the Rhima Service Department.
B4	FAILURE IN RINSING	Contact the Rhima Service Department.
B5	BOILER OVERTEMPERATURE	Contact the Rhima Service Department.
E1	WASH-TANK NOT FILLED	Open the water supply tap. Contact the Rhima Service Department.
E2	WASH-TANK SENSOR FAILURE	Contact the Rhima Service Department.
E3	WASH-TANK NOT HEATED	Contact the Rhima Service Department.
E5	WASH-TANK OVERTEMPERATURE	Contact the Rhima Service Department.
E7	WASH PUMP THERMAL RELAY	Contact the Rhima Service Department.
Z7	ROTATION MOTOR THERMAL RELAY	Contact the Rhima Service Department.

table 4

TROUBLESHOOTING

Type of Problem	Possible Causes	Cure
The appliance does not draw water	The water tap is closed.	Open the water tap.
	Solenoid-valve filter blocked	Contact the Rhima Service Department.
	Faulty pressure switch.	Contact the Rhima Service Department.
Granules: Insufficient quantity	---	Add or substitute granules up to the filter dispenser level.
Unsatisfactory washing results	The washing nozzles are clogged or the washing arms do not rotate.	Unscrew and clean the nozzles and the rotating column, refit them correctly in their seats.
	Unremoved grease or starch	Detergent concentration too low.
	Presence of foam.	Use non-foaming detergent or use less of same detergent.
	The filter is too dirty.	Remove the filter, clean it with a brush under running water and refit in its seat.
	Check tank temperature (which must be between 50°C and 60°C).	Contact the Rhima Service Department.
	Length of washing cycle inadequate for type of grime build-up.	Choose a longer cycle if possible, otherwise repeat wash cycle.
	Wash water too dirty.	Empty water from the tub, clean filters; refill the tub and correctly reposition the filters.
The objects are not properly dried.	Insufficient rinse aid.	Increase the amount of rinse aid. Contact the Rhima Service Department.
	The rack is not suitable for the objects.	Use the suitable rack which gives the objects an inclined position so that water can rinse away.
	The washed items may have been sitting in the wash chamber too long.	As soon as the cycle stops, remove the rack with the objects so that they can dry more quickly in the air.
	Rinse temperature under 80°C.	Contact the Rhima Service Department.
	The rinse water is cold or not hot enough.	Contact the Rhima Service Department.
Streaks and spots on glasses and dishes	Too much rinse aid.	Decrease the amount of rinse aid. Contact the Rhima Service Department.
	The water is too hard.	Check the water hardness. Water should not be harder than 2-8 °f.
During wash cycle the machine stops and draws water	Water from the previous day has not been replaced.	Empty the tub and refill it.
	The tub water temperature is too high.	Contact the Rhima Service Department.
	Faulty pressure switch.	
Machine will not drain	Object stuck in drain pump*.	Contact the Rhima Service Department.
	Blocked drain.	Check sink's drain correctly. If not contact licenced plumber.

* If drain pump is supplied.



Australia

Tel: 1300 347 944

New Zealand

Tel: 0800 902 054

Singapore

Tel: +65 9107 8943

DETERGENTS

To request detergents or rinse additive contact your local Rhima Service centre below:

Australia: **1300 347 944**

New Zealand: **0800 902 054**

Singapore: **+65 9107 8943**



Granules

9kg Bucket

For washing glass &
instrument washing

