

Rhima DEKO 190GT

Ward washer disinfector



Rhima Australia
www.rhima.com.au
Rhima New Zealand
www.rhima.co.nz
Rhima Singapore
www.rhima.sg





DEKO 190

The Deko 190 is designed and constructed to meet the standard performance and design requirements stated in ISO EN 15883-1 Washer-disinfectors - Part 1 and Part 3: Requirements and tests for washer-disinfectors employing thermal disinfection for human waste containers.

UNIQUE WASHING EFFICACY

Thanks to the unique, patented fresh water recirculation principle of the Deko 190, the machine has a minimal need for energy and water in relation to the capacity and efficacy of the adjustable process cycles. Also the thermal disinfection of outlet, water tank and pipework in every cycle is of great importance and only available in the Deko 190.

Deko 190 is intended for emptying, flushing, cleaning and thermal disinfection of reusable waste containers such as;

- supports for single-use bedpans
- hospital wash bowls
- urine bottles
- mop buckets
- suction bottles
- measuring jugs
- vases
- overshoes
- and all other reusable products used for similar purposes within patient care

POWERFUL PROCESS

Process results are guaranteed throughout:

- water pressure for washing is supplied by a high powered 600L/min recirculation pump
- detergent is automatically dosed into the recirculated water by a pump
- the unique working principle facilitates cleaning and steam
- disinfection of the entire system including wash chamber, water tank and outlet with minimal water and energy usage
- disinfecting steam is generated by an integrated unpressurised boiler and run through the water tank, outlet and internal pipework
- wide selection of disinfection temperatures and cycle set-ups to secure the microbial inactivation impact

Cycles can be altered to meet almost any special requirement, though the standard requirements are met with the fixed, tested and approved cycles pre-programmed by the manufacturer.

The access code system protects any unauthorised changes to the set parameters. The washing spray patterns are delivered through 3 rotating + 7 fixed spray jets guaranteeing contact with all surfaces and crevices of items with varying design.

VERSATILE

Deko 190 has a large wash chamber and capacity for automatic emptying and processing of 2 bedpans with lids and 4 urine bottles simultaneously. The integrated drop down shelf provides space for 4 hand wash basins or a mop bucket. The shelf can also be utilised as a base to accommodate inserts and washing accessories to process eg.

- disposable bedpan supports
- kidney dishes
- bowls
- raised toilet seats
- vases
- toilet brushes/holders
- various hollowware

Using optional holders and baskets enables the correct positioning and easy loading of various items, such as suction jars and medicine pots, and extends the capacity and versatility of the Deko 190.



MAIN FEATURES

- 3 rotating + 7 fixed wash jets
- automatic detergent dosage
- indication for insufficient volume of detergent to complete cycle
- integrated detergent container housing
- load temperature protection and over temperature cut-outs
- automatic foam and washing water pressure control system
- opaque cold and hot water connection hoses 1/2" BSP
- drain outlet diameter 90-100 mm
- sound and heat insulated
- vapour condenser
- height adjustable feet ± 10 mm
- overall dim. W600 x D630 x H1460 mm
- usable wash chamber dim. W480 x D360 x H640 mm
- powerful circulation water pump, output 600 L/min
- cycle phase indication
- display indicates cycle completion
- fault indication and coded information
- access to regulation of critical process parameter values with authorised person entry code only
- component test mode for preventative maintenance
- lockable door for chemical container

OPTIONS

- descale dosage pump
- audible cycle end indicator
- back syphon Type A air gap protection (when required)



The Deko 190 is controlled through a Programmable Logic Controller (PLC) that is the most advanced operating system available today. The display provides clear and informative user and service instructions. To operate the Deko 190 simply select the appropriate pre-programmed cycle and press the button - the PLC takes care of the rest. The following are all verified and presented on the easy to read display:

- selected cycle
- batch number
- current cycle phase
- chamber temperature
- washing pressure
- cycle time

The PLC's process control and independent recording accuracy are compliant with the most stringent requirements of ISO EN 15883-1 & 3 for washer disinfectors. The maintenance and service file system restores valuable information for technical performance follow-up and evaluation.

RELIABLE QUALITY

The Deko 190 is manufactured of quality polished stainless EN 1.4301 steel, it is easy to keep clean and can withstand continuous use. Special attention has been paid to sound and hear insulation by using the most efficient and environmentally friendly materials. Durability and reliability in continuous, heavy and busy institutional operating circumstances have been the key factors in the design of the Deko 190.



ACCESSORIES



242.1002.120

Shoe rack - 4 pairs (381 450)



242.1002.059

Utensil basket with a lid
340 x 250 x 200 mm (381 170)



242.1002.126

Suction bottle rack (381 690)
as per given bottle dimensions



242.1001.090

Instrument tray
450 x 340 x 70 mm (381 200)

242.1001.088

Instrument tray
250 x 170 x 70 mm (381 220)



242.1002.112

Peg rack - 12 places (381 515)

242.1001.095

Lid 450 x 340 mm (381 201)

242.1001.097

Lid 250 x 170 mm (381 221)

242.1001.089

Instrument tray
340 x 250 x 70 mm (381 210)

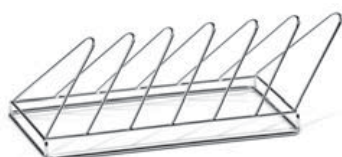

242.1001.076

Kidney dish rack - 6 places (381 685)

242.1001.096

Lid 340 x 250 mm (381 211)



242.1002.121

Urine bottle insert - 4 pieces (381 680)

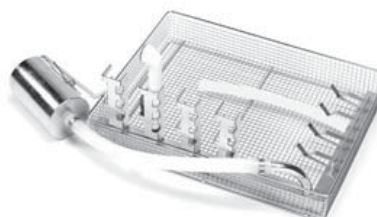

242.1002.123

Insert for oras shower handles and hoses - holds 4 handles and hoses (381 683)

TECHNICAL DATA

Outer dimensions

Width	600 mm
Depth	630 mm
Height	1460 /*1610 mm
Weight	130 kg
Gross wash chamber volume	72 L

Inner dimensions

Chamber height	640 mm
Chamber width	480 mm
Chamber depth	360 mm
Water volume / one cycle phase, excl disinf.	9 L

Electricity

240/400V 3N 50Hz 7.5kW 16A or,
240/400V 3N 50Hz 6.6kW 10A or,
120/208V 3N 60Hz 6.6kW 19A
Further details at request

Capacity & effects

Heating power	6.6 or 7.5kW
Circulation pump 600L/min	1.5 kW
Outlet size diameter in	90/110 mm
Cold water hose L= 2 m	G1/2"
Hot water hose L= 2 m	G1/2"

Min/Max water pressure 1/8 bar

Detergent container housing

Models

- electrically heated
- steam heated*
- manual door

*For steam operated machines please contact us

Please note: Subject to change without notice.

Included as standard

- holder for 2 bedpans
- 4 urine bottle nozzles
- fold down wash shelf
- detergent pump
- detergent container housing

Certificates / tests / approvals

- ISO 14001
- ISO 13485
- ISO EN 15883-1, 15883-3
- IEC 61010-1
- IEC 61010-2-040
- IEC 61326-1
- CE 0537

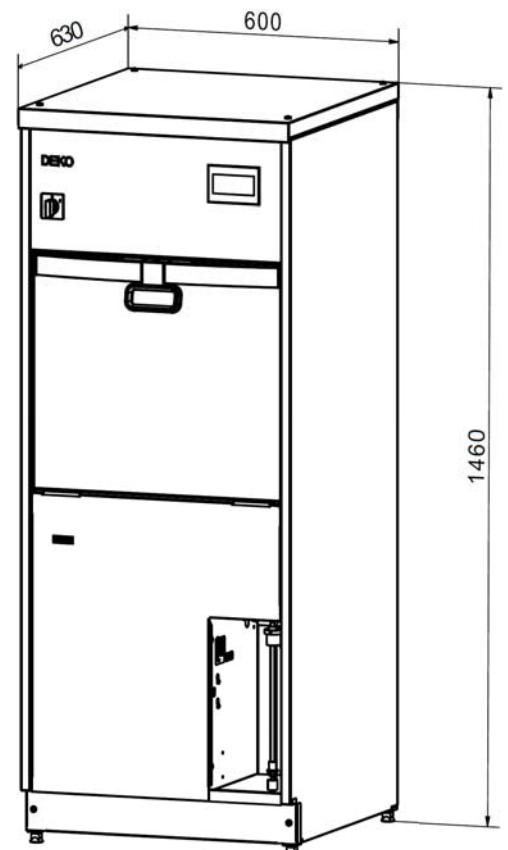

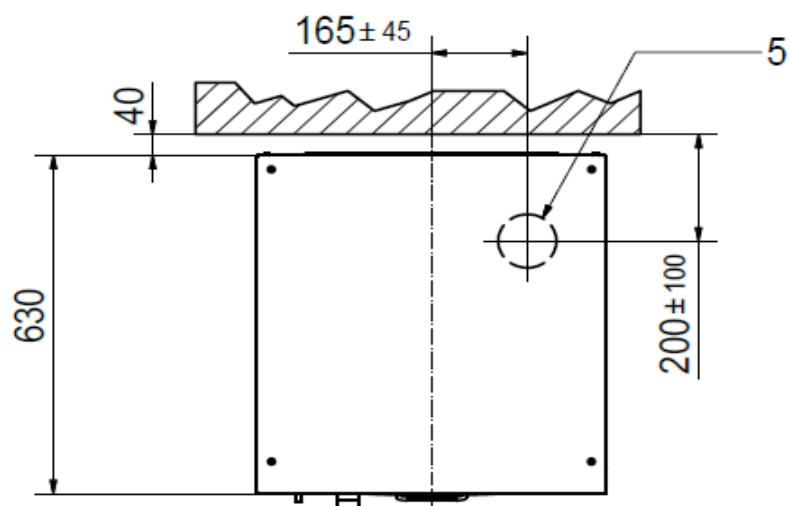
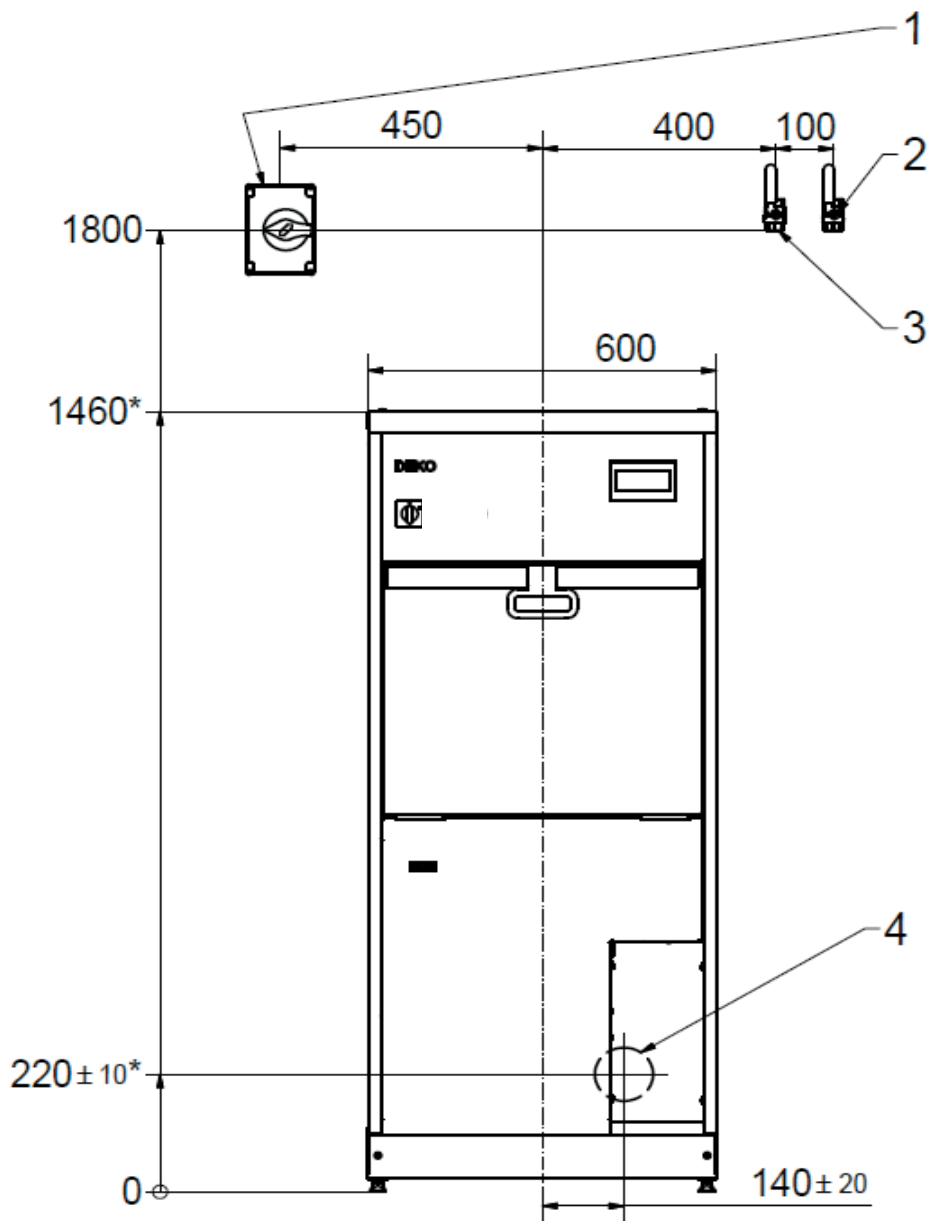

RHIMA CARE

SERVICE AND MAINTENANCE FOR YOUR WASHER

Does my washer/disinfector need regular service and maintenance?

Whether your Rhima washer/disinfector is in or out of warranty, it needs regular professional maintenance to ensure it is operating at optimum performance. Regular maintenance can also reduce running costs and greatly extend your washer's useful life. As importantly, a well serviced machine helps to safeguard against unexpected, inconvenient, expensive breakdowns.

Does my washer/disinfector comply with ISO 15883 and AS1487 standards?

Rhima provides thermal validation services that comply with Australian and international standards. Our specialist validation technicians are trained in the use of highly sophisticated, calibrated test equipment and will ensure that your washer/disinfectors meet these strict standards for disinfection. The validation services that Rhima provide should not be confused with a simple 'temperature check' offered by other providers which do not comply to either standard. While performing the validation service on each machine, Rhima technicians also perform a full preventative maintenance on the machine, ensuring that your washer/disinfectors are performing to manufacturer's specifications.



My washer needs to be fixed and it's 11AM on a Sunday morning. Who do I call?

Rhima provides professional washing equipment to professionals just like you. We understand that businesses do not all operate 9 to 5 and neither do we. Call us at any time and a service representative will respond to your call. Our first priority is to try to get you operational over the phone, however if this is not possible, you will be given the option of waiting until the next business day to log a service call or if you can't wait, then in most cases a service technician will be arranged to attend your premises as soon as possible, usually same day.

BENEFITS OF RHIMA PREVENTATIVE MAINTENANCE

- Confidence that your washer/disinfectors meet international and Australian standards
- Improved washer efficiency and reliability
- Priority service in the event of repairs being required
- Reduction in unexpected breakdowns and costly stoppages
- Savings on total maintenance costs
- Optimisation of detergent and rinse additive usage
- Prolonged service life
- 24/7 service response
- First 2 hours of labour on breakdowns*

*Callout fee applies. Not valid for faults not directly related to washer i.e., interruption to services (power, water & drainage) or operator

We can tailor a Rhima Care Validation and Preventative Maintenance Agreement to suit your needs.

CLEANING AND CARE

CHEMICALS FOR USE WITH YOUR RHIMA EQUIPMENT

Detergents available in Australia **MEDIWASH 5 Litre**

A non caustic, non chlorine washing liquid that gives superior results in our range of glasswashers. Only to be used in combination with automatic dispensers. This detergent is TGA approved. Available in 2 x 5L carton.



Detergents available in New Zealand **MEDIWASH 2.0 - 5 Litre**

Detergents available in Singapore **RHIMAWASH - 5 Litre & 20 Litre**



rethink
○ *reuse*
rhima



Rhima Australia Pty Ltd
www.rhima.com.au
Tel: 1300 347 944

Rhima New Zealand
www.rhima.co.nz
Tel: +64 9414 5575

Rhima Singapore
www.rhima.sg
Tel: +65 9107 8943