

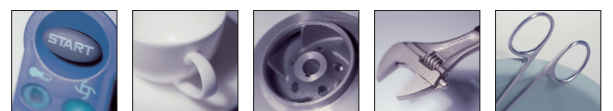

■■■ **Deko-260**
washer-disinfector

rhima
the power of clean



■■■ Deko-260 is a microprocessor controlled cabinet washer-thermal disinfecter for professional use in hospitals and laboratories. Its cleaning and disinfection efficiency have been stringently tested and approved internationally.

Deko-260 is available with or without a dryer. The structures are made of stainless AISI 304 and acid-resistant AISI 316 steel, and its components selected on the basis of stringent tests. In addition to durability, efficiency and dependability, special attention is also paid to the many-sided and trouble-free performance of the machine.



■■■ Control

A microprocessor provides the selection of 5 different programmes. Wash water temperature can be adjusted to enable the cleaning of surgical instruments, rubber and plastic goods, as well as glassware. The disinfection temperature and time are being programmed in accordance with the existing standards and can be regulated by using special codes. In cases of malfunction, a red indicator comes on and, if the set values for disinfection time & temperature have not been reached, the door does not open. A security lock also prevents it from opening while the machine is running. A chart recorder or printer and a cycle counter are optional.

■■■ Construction

Deko-260 has rotating wash arms and an automatic connection for spray racks injecting water inside cannulated instruments, hoses and bottle type glassware. Design of the demountable wash arms secures a complete contact with all parts of the load and the wash chamber and allows easy cleaning of the spray holes. Dosage of liquid detergent is carried out automatically by means of a pump and can easily be regulated for agents with varying concentration. Extra detergent pump, wetting agent pump and distilled water feed are available as options. The shelves are mounted on slides and are fully removable.

■■■ Programmes

The machine comes with three different washing programmes as standard. As needed, two other programmes can be utilized. Their content can be tailored to the customer's wishes. Depending on the number of selected phases, the programmes normally last from 10 to 60 minutes. In models with an integrated drying unit drying time and temperature are regulated independently.

■■■ Features

- 5 variable programs
- door window
- 3 rotating wash arms
- 2 sliding wash levels
- automatic connection valve for spray racks
- wash water temperature adjustment
- digital thermometer
- automatic detergent dosage
- programme phase indicators
- door safety interlock
- hot and cold water connections
- outlet pump and water trap
- over-temperature cutout
- overflow protection
- fault indicator and code system
- sound and heat insulation
- thermocouple entry port

■■■ Models

DEKO-260 D (L)
DEKO-260 E (L)
Integrated dryer:

D = steam heated
E = electrically heated
K = including a dryer
L = laboratory model



■■■ Construction and equipment

The Deko-260 is easy to install and service. The machine's connections and those of its parts which require adjustment are situated towards the bottom of the machine. The hot and cold water connections come equipped with check valves, back valves, mud filters and siphonage protection. The flexible connection hoses are standard equipment, as the Ø 20 mm outlet hose. The electrical cable is 2 m long, the connection semifixed. In laboratory models, the distilled water feed is accomplished by either a solenoid valve or a separate pump. In the steam heated model the condensate connection is also flexible.

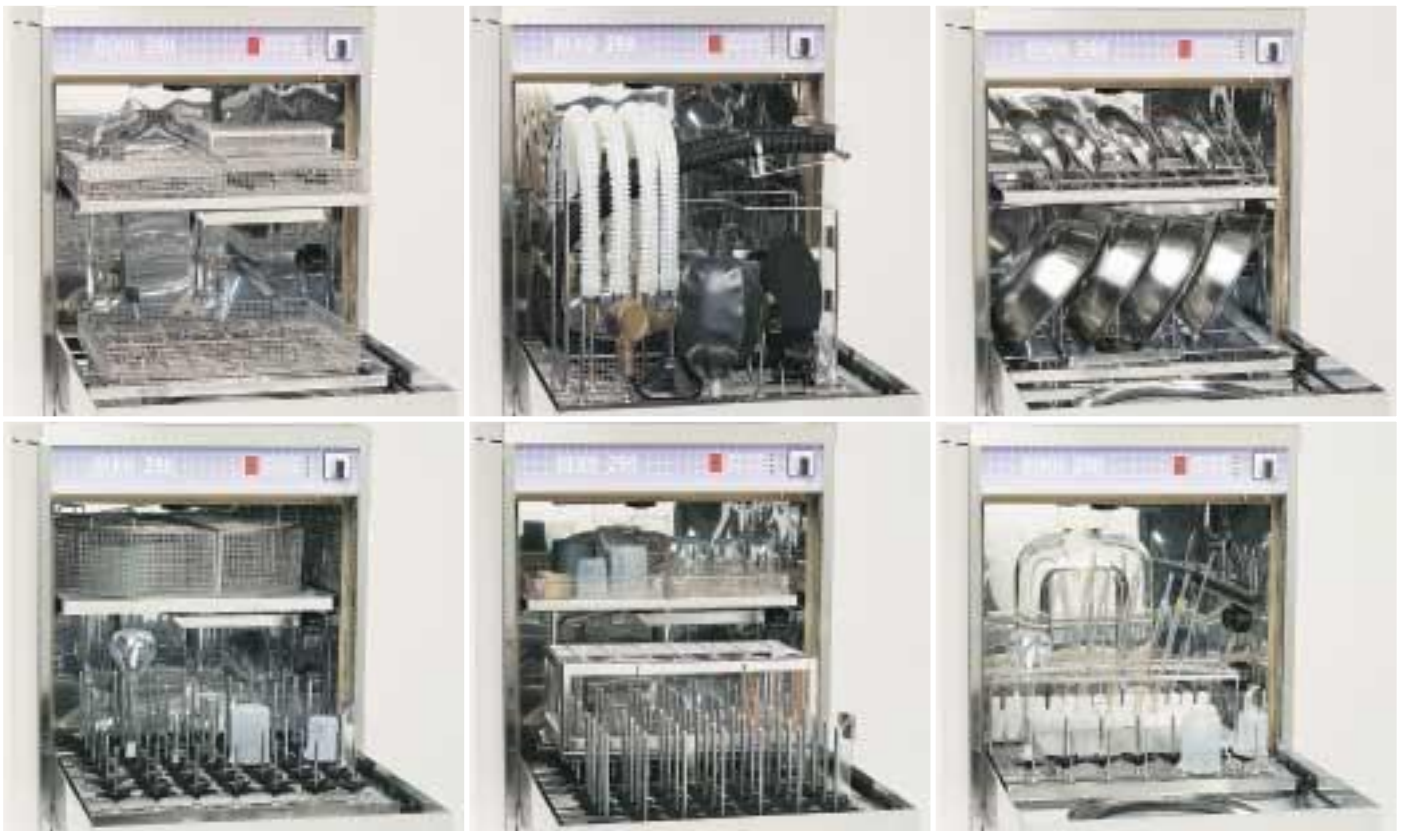

■■■ Operation panel

- main switch
- function indicators
- programme selection and start buttons.
- +/- washing water temp. adjustment buttons.
- digital thermometer, programme & phase display, service code indication.



■■■ Program example

- cold water rinse
- circulation wash with detergent
- warm water rinse
- disinfection >85 °C / 1, 2, 5, 10 minutes.
- ...93 °C/10 minutes

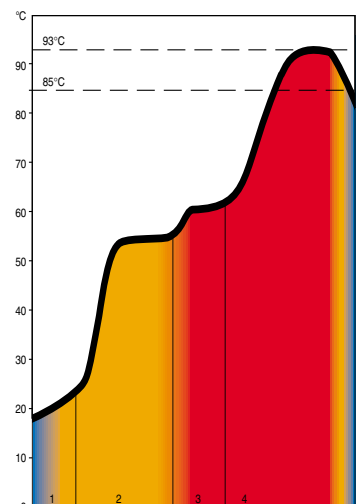

■■■ Instruments

Though developed for the cleaning of medical instruments and anaesthesia equipment, DEKO baskets and racks also serve as storage and carrying baskets.



①



③



⑤



⑦

1.

381200 Instrument tray 450 x 340 x 70
 381210 Instrument tray 340 x 250 x 70
 381220 Instrument tray 250 x 170 x 70
 381201 Lid 450 x 340
 381211 Lid 340 x 250
 381221 Lid 250 x 170

2.

381202 Inner tray 430 x 320 x 50
 381212 Inner tray 320 x 230 x 50
 381222 Inner tray 230 x 150 x 50
 381203 Lid 430 x 320
 381213 Lid 320 x 230
 381223 Lid 230 x 150

3.

381300 DEKO 1/2 basket
 440 x 290 x 180
 381301 Divider

4.

381170 Utensil basket
 340 x 250 x 200 incl. lid

5.

381426 Washing rack for suction tubes

6.

381421 Rack for anaesthesia equipment

7.

381341 Washing rack for sigmoidoscopes

8.

381351 Washing rack for Bird hoses

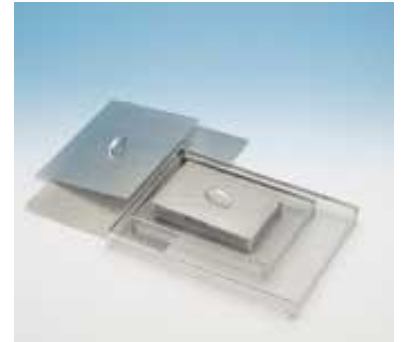

②



④



⑥



⑧



⑨

- 9.**
381316 Rack for anaesthesia equipment
for machines incl. a dryer

- 10.**
381345 Rack for rigid scopes

- 11.**
381441 Shoe rack

- 12.**
381685 Kidney bowl rack



⑩



⑪



⑫

■■■ Shelves

The same washer is used for both hospital instruments and laboratory glassware. By switching washing shelves, the user can apply the DEKO washer to many different purposes.



①

- 1.**
381021 Middle shelf for hospital
instruments (incl. washer arm)

- 2.**
381011 Middle shelf for laboratory use
(incl. washer arm)



②

■■■ Laboratory



①

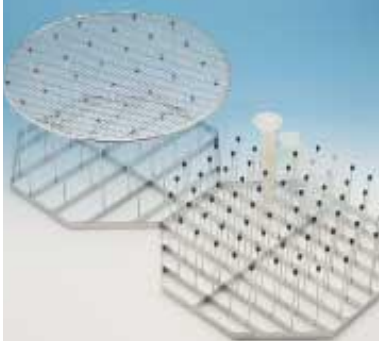

③

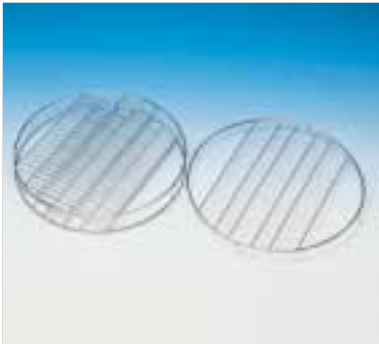

⑤



⑦



⑨

The versatile equipment makes the cleaning of laboratory glassware easy and efficient.

1.

381500 Sector basket H = 135
381501 Lid
381510 Sector basket H = 210
381502 Divider H = 50
381503 Divider H = 90
381504 Divider H = 125
381505 Divider H = 180

2.

381515 Pegged rack

3.

381520 Pegged rack H = 150
381530 Pegged rack H = 250
381535 Pressure lid

4.

381540 Microscope-slide rack

5.

381550 Petri dish rack

6.

381578 Washing carriage for pipettes

7.

381580 Washing rack for beakers

8.

381566 Washing rack for graduated flasks

9.

381533 1/1 lid
381534 1/2 lid
- for rack 381566

10.

N23658 Support star for bottles, Ø 8 mm tube
N23659 Support star for bottles, Ø 6 mm tube
N24366 Height adjustment spring,
Ø 8 mm tube
N24435 Height adjustment spring,
Ø 6 mm tube
381557 Bottle holder, Ø 6 or 8 mm tube

11.

381725 Tension key for spray tubes



②



④



⑥



⑧



⑩



⑪

■ ■ ■ Dental equipment



①



③

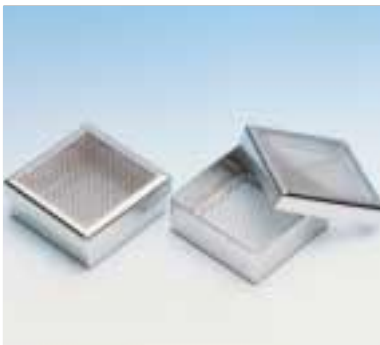

⑤

■ ■ ■ Bottles



①



③

The baskets and racks developed for various dental equipment cleaning needs, are well suited to the various DEKO washer models. Washing racks are also manufactured according to the customer's wishes.

1.

381215 Instrument tray with end plates
340 x 250 x 70

381211 Lid 340 x 250

381216 Rack for instrument trays

2.

381217 Compartment for mirrors

3.

381396 Washing rack for saliva- and suction tubes

4.

381677 Dental tray rack

5.

381230 Fine mesh box for needles and bore bits 90 x 90 x 40

6.

381398 Rack for hoses



②



④

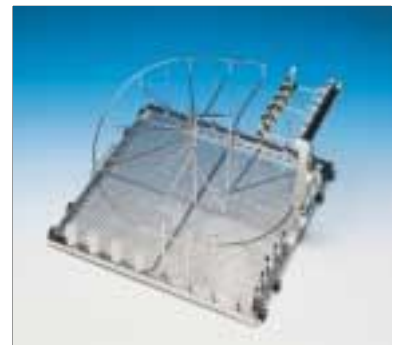

⑥



②

For bottle washing, rack compartments and spray racks for various bottle sizes are supplied to laboratories and baby milk centers.

1.

381600 Bottle compartment, bottle 100 g

381601 Lid

381605 Bottle compartment, bottle 250 g

381606 Lid

381610 Bottle compartment, bottle 500 g

381721 Lid

2.

381602 Bottle washing rack bottle 100 g

381607 Bottle washing rack bottle 250 g

381722 Bottle washing rack bottle 500 g

3.

381604 Bottle washing rack,
custom made



■ ■ ■ Connections

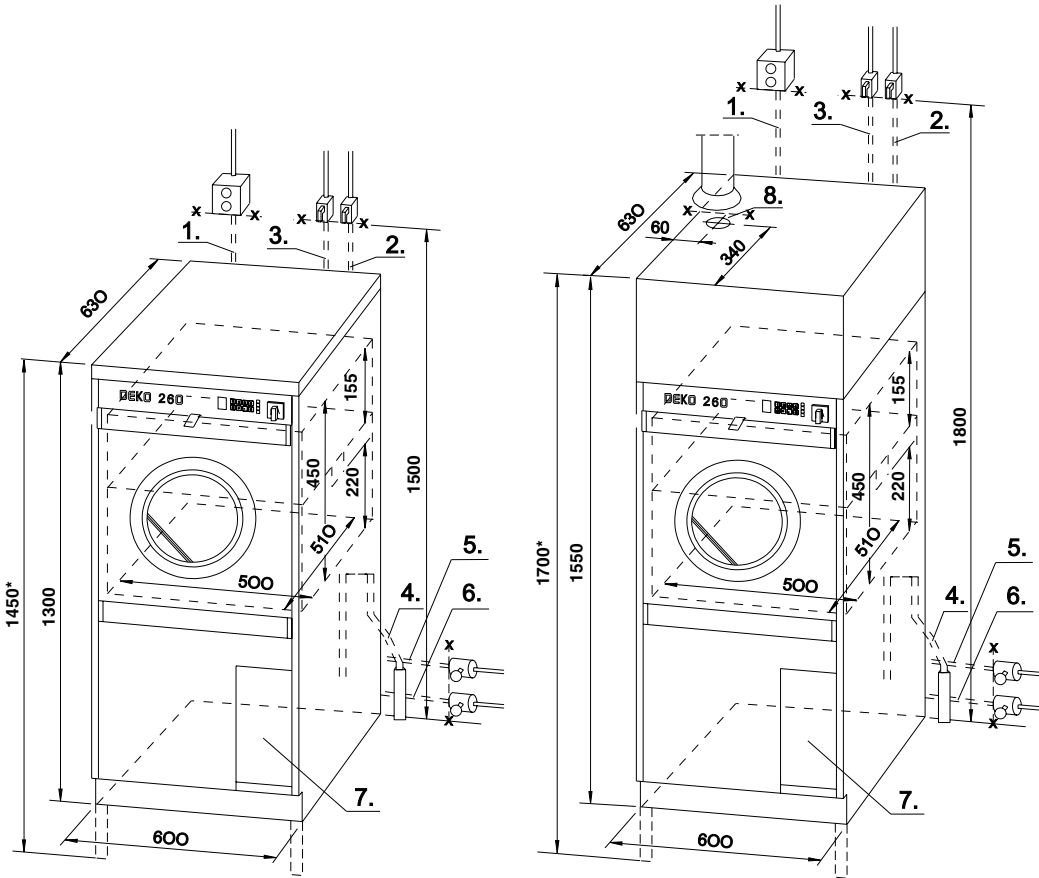

1. Electricity
230/400V 3N 50Hz 9 kW
Fuses 3x16A
208/240V 3N 60Hz 9,5 kW
Fuses 3x27A
Other voltages at request.
2. Cold water, R 1/2", L=3 m
3. Warm water, R 1/2", L=3 m
4. Outlet dia 20 mm, L=2 m
5. Steam*, R 1/2", L = 1,2 m
6. Condensate*, R 1/2", L = 1,2 m
- * = only in steam heated D -models.
7. Place for detergent container
8. Ventilation, dia 90 mm
Heating power 7,5 kW
Dryer 2.9 kW (option)
Circulation pump 1,5 kW,
600 L/min
Outlet pump 85 W, 28 L/min
Water consumption: 10 L/rinse
12 L/wash
Distilled water pump 0,5 kW
Min/max water pressure 1/8 bar.
15/115 psig
Flow rate 0,5 L/sec.
Heat transmission appr. 700 W
Steam pressure 2-3 bar (in D -
models)
5-45 psig
Net weight 95 kgs/213 lbs.

1450* and 1700*
are for machines with
150 mm high legs

CE-marked.

Subject to changes without further notice.

■ ■ ■ Deko range



Deko-25

Deko-2000

Deko-2000 K

Deko-190

Deko-260

Deko-260 K