

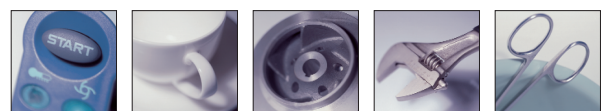

DEKO 2000

Washer-disinfector





Loading side view

RELIABLE PERFORMANCE

The DEKO 2000 is designed and constructed to meet the performance and design requirements stated in EN ISO 15883-1 Washer-disinfectors - Part 1: General requirements and in Part 2: Requirements and tests for surgical instruments, anaesthetic and respiratory equipment, hollowware, utensils, glassware etc., as well as, the safety requirements stated in IEC 61010-2-40: Particular requirements for washer-disinfectors used in medical, pharmaceutical, veterinary and laboratory fields.

Process results are guaranteed throughout:

- water pressure for washing is supplied by a high powered 800 litres per minute circulation pump
- pipework and the number of loading shelves fitted with rotating spray arms are calculated to have the maximum soil removal efficacy
- wide selection of disinfection temperatures and cycle times to secure the microbial killing impact
- fast HEPA filtered drying

Cycles can be altered to meet almost any special requirement, though the standard requirements are met with the fixed, tested and approved programs inserted by the manufacturer.

The washing spray patterns are delivered through five rotating spray arms and purpose designed racks to guarantee the contact with all surfaces and crevices of instruments with the most intricate design.

PLC CONTROL

The DEKO 2000 is equipped with a Programmable Logic Control system. The user interface with a graphic display provides clear instructions and information on the operation and on-going cycle.

Pass-through models have in addition also indicators at the unloading side for on-going cycle, process completed and fault.



SAFETY AND COMFORT

The DEKO 2000's compact dimensions are based on thorough ergonomic research and practical studies. The opening height of the doors, all controls at eye level and flexible usage of the wash chamber with individually removable shelves make the DEKO 2000 simple and comfortable to work with.

With the horizontally front-opening doors, separate transfer carts can be avoided and the loading and unloading is made easier, safer and more hygienic. Any residual fluid dripping from the load is collected on the inner door surface, which is washed and decontaminated during each completed cycle.

The doors open & close smoothly and are locked securely throughout the cycle.

Clear text on the display and a green indicator light will advise when the doors are unlocked for opening. An audible indicator may be added to draw attention to the ending of the cycle.

Shockproof windows allow a visual check upon the status in the wash chamber.

All parts of the machine and washing accessories coming into contact with the processed items are being cleaned and disinfected simultaneously and separate manual handling is unnecessary.

VERIFYING THE PROCESS DATA

In order to guarantee that the values of the critical process variables were truly obtained and as programmed, the DEKO 2000 is equipped with an integrated process verification printer.

The optional model with a 5.7" TFT Touch Screen Operator and Display Panel can also download cycle information directly through Intranet or save data on a USB Memory Stick, i.e.: institution name, date and time, operator and machine identification, cycle number, selected cycle name, phase descriptions, washing pressure, detergent dose stage and volume (option), chamber temperature throughout the process and faults.



Standard LCD display & User Interface and the integrated process verification printer.



Unloading side view

FOR THE PROFESSIONALS

The DEKO 2000 is manufactured by polished stainless AISI 304 stainless steel, it is easy to keep clean and can withstand continuous use. Galvanised and painted metals and other non-compatible materials are totally avoided in the manufacture of the DEKO 2000. Special attention has been paid to sound and heat insulation by using double sheet constructions and the most efficient and environmentally friendly materials.

Durability and reliability in continuous, heavy and busy institutional operating circumstances have been the key factors in the design of the DEKO 2000.

RELIABILITY

The DEKO 2000 occupies its space efficiently. One unit requires only W800xD710 mm of floor space. Connections to water, electricity, drain and ventilation are provided with all necessary safety features. Regular control & maintenance of the machine is made quick and easy by the service mode of the PLC and easily accessible components. Water is taken into the chamber directly to avoid separate cleaning and disinfection of integrated water holding tanks. User and Maintenance Manuals include all relevant details and instructions as required. Any information, advice, personnel training and service calls are attended to with the utmost dedication and urgency. Availability of spares is guaranteed for the minimum of 15 years after date of shipment and the complete programme and software lodged securely with an independent body.

EASE OF USE

The advanced control system allows setting up practically an unlimited number of tailored programs. There is an option of 3 most commonly used cycles available at the touch of a button and a cycle memory library with scroll selection. Process parameters are protected by special codes and a number of tested and approved cycles can be set fixed, only to be altered by the manufacturer. Use of the machine solely by authorised and trained personnel is facilitated by a 3-level access code system. Accurate instrumentation and the fast processor secure that the circumstances in the process are held within the pre-set limits in order to obtain the required cleaning and disinfection result. Protection to thermo-labile medical devices is provided by double overheating prevention.

Cleaning efficacy is increased by dosing automatically the precise adjusted volume of one or more detergent at the correct time of the wash cycle. Containers are safely positioned into an easy accessible opening that can be supplied optionally with a lockable door for added safety. The intelligent control system monitors the washing pressure constantly and secures the achievement of the pre-set process values.

Advice when detergent volume is running low is given at the start of five consecutive cycles. If the volume is insufficient for the selected process then the cycle will not start.

SUMMARY OF FEATURES

- overall dim. W800xD710xH1970 mm
- usable wash chamber dim. W600xD610xH610 mm
- electricity U 400V 3N AC 50Hz (or 60Hz), max 13 kW, 3 x 25A. Other voltages as required.
- powerful circulation water pump, output 800L/min
- framework, panels and wash chamber all made of stainless steel. No mild steel or galvanized steel frame constructions.
- interlocking opening doors provided with springs and safety locks
- fully automatic PLC control including back-up batteries for full memory protection
- 3+1 cycle selection & start keys
- phase indication as text
- remaining program time indication
- cycle complete indication as text and with a green led
- fault indication
- multi-level access code system. Special codes for: user, maintenance, authorized person
- secure tested cycle files
- customized cycle files
- access to regulation of critical process parameter values with authorized person entry code only
- in-process indication
- cycle & phase info
- remaining cycle time
- unloading end:
- in-process indication
- cycle complete: green led
- fault indication: red led
- independent process verification recording system
- integrated process verification printer
- information:
 - institution name
 - date and time
 - machine number
 - non-resettable cycle number
 - cycle name and configuration
 - cycle start and end time
 - temperature recording throughout the cycle
 - fault identification and registering
- special service and maintenance control system
 - malfunction identification in code format
 - adjustment of controls
 - calibration of measuring instruments
 - manual override step by step
 - component test mode
 - error listing
 - updates by a PC and memory card
 - no need to program the functions of individual electrical components
- 4 independently removable, sliding wash shelves
- automatically connecting / closing wash arm connectors
- 5 rotating wash arms with removable caps facilitating easy cleaning of the inner surfaces of the wash arm. No tools required for removing the wash arms.
- adjustable automatic detergent dosage pump
- indication for insufficient volume of chemicals to complete cycle
- place for process chemical containers
- boss entry port for test temperature sensor leads
- high efficiency dryer with a pre-filter and a HEPA filter Class H13
- ventilation connection provided with a spigot up-stand sleeve and condensate back-flow protection
- filter quality monitoring and change indication system
- drying mode may be used individually
- load temperature protection and overtemperature cut-outs
- automatic foam and washing water pressure control system
- opaque cold and hot water connection hoses ½" BSP
- drain outlet diameter 50 mm
- sound and heat insulated
- shockproof window(s)
- height adjustable feet
- stainless steel side panelling
- back syphon Type A air gap protection
- shut-off isolator valves
- mutable process complete buzzer



TECHNICAL DATA

Type	DEKO 2000
Outer dimensions mm:	
Width	800
Depth	710
Height	1970
Weight kgs	250
Usable chamber volume L	
220	
Usable inner dimensions mm:	
Chamber height	600
Chamber width	600
Chamber depth	610
Wash levels	4
Usable height/level, mm	
95/135	
Wash arms max.	
5	
Basket capacity:	
SPRI basket 1/2, 340x250x70 mm max.	16
DIN 480x255x50 mm max.	8
DIN 240x255x50 mm max.	16
DIN 120x255x50 mm max.	32
EURO 600x300x70 mm max.	8
EURO 300x300x70 mm max.	16
EURO 150x150x70 mm max.	32
Water filling volumes L/one phase:	
Rinse	19
Wash	19
Disinfection	19
Electricity	
U 400V 3N AC 50/60Hz, E-models	3x25A
U 400V 3N AC 50/60Hz, D-models	3x16A
U 200-240V 3PH AC 50/60Hz, E-models	3x35A
U 200-240V 3PH AC 50/60Hz, D-models	3x16A
Capacity & effects:	
Total power kW, E-models	12,8
Heating power kW, E-models	10 or 7,5
Dryer kW	6.0
Circulation pump kW	2.8
Outlet size diameter in mm	50
Purewater pump kW, optional	0.5
Water flow L/sec	
0,5	
Steam consumption kg/min, D-models	
0,5	
Condense return kg/min, D-models	
0,5	

MODELS:

E = electrically heated
D = steam heated
X = pass-through
L = laboratory
K = dryer

E.g. Deko DEKO 2000EXLK =
electr. heated pass-through
laboratory model incl. dryer

Note. Available also excl. dryer.

INCLUDED AS STANDARD:

- 4- level shelves
- 5 wash arms
- 1 detergent pump

TESTS/APPROVALS:

ISO 9001
ISO 14001
ISO 13485
SIS TR-3:2001
EN ISO 15883-1, 15883-2
IEC 61010-2-40
CE 0537

Subject to changes without further notice. Please ask the supplier for confirmation as required.

OPTIONS

- excluding dryer
- max. 2 extra detergent pumps
- max. 1 adjustable rinse aid pump
- solenoid valve, feed pump and hose for purified water
- detergent dose volume verification (optional)
- washing pressure registering (optional)

OVERALL DIMENSIONS AND MASS

OUTER DIMENSIONS:

Width M_w 800 mm
 Depth M_d 710 mm
 Height M_h 1970 mm
 Loading height above floor L_h 850 mm

CHAMBER DIMENSIONS:

Width C_w 600 mm
 Depth C_d 610 mm
 Height C_h 610 mm
 Volume 347 / 220 L (0.22 m³)

LEVELS:

Lower level L_1 min/max 95/135 mm
 Middle level L_2 min/max 95/135 mm
 Middle level L_3 min/max 95/135 mm
 Upper level L_4 95 mm

MASS:

Weight with drying unit 250 kg
 Weight without drying unit 230 kg
 Floor loading 0.05 kN/cm²

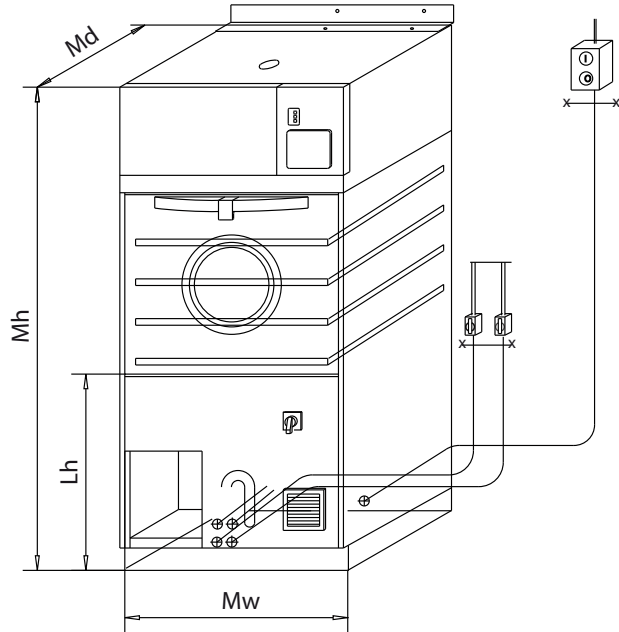

INSTALLATION

Installation of single door machine

Pass through model, 1-unit

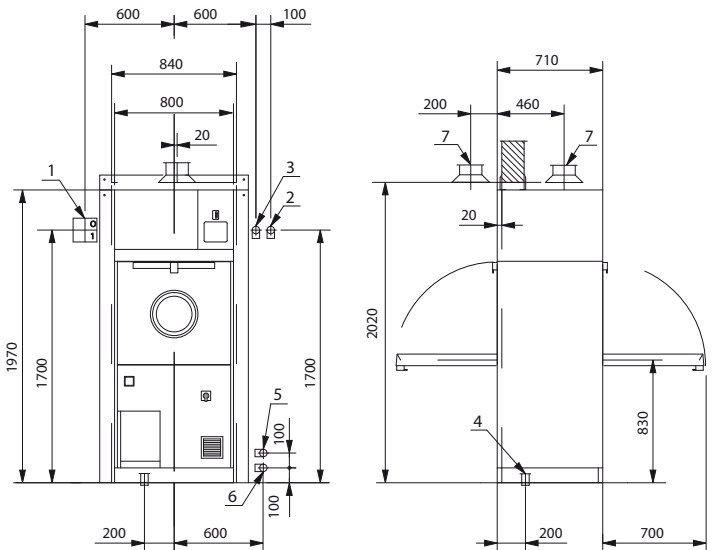
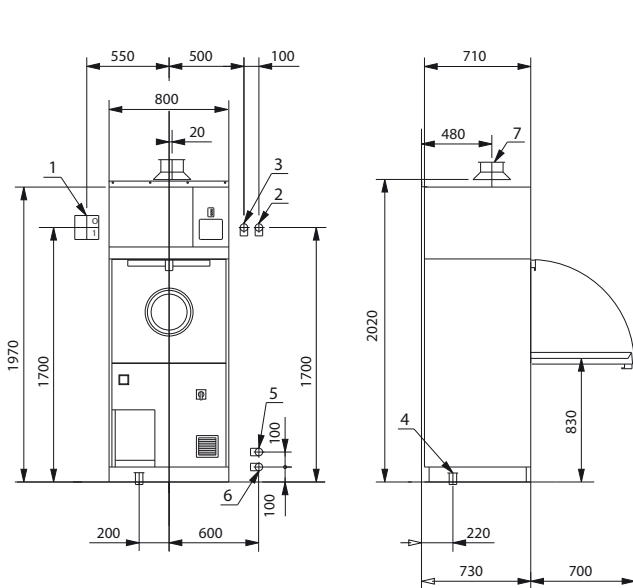

1. Circuit breaker (supplied by the buyer)
2. Cold water R1/2" (female), shut off valve (supplied by the buyer)
3. Warm water R1/2" (female), shut off valve (supplied by the buyer)
4. Drain outlet NS dia 50 mm
5. Steam connection R1/2" (male)
6. Condensate connection R1/2" (male)
7. Exhaust duct dia 90 mm

Wall opening for pass-through model, side by side installation
 Width of wall opening is $n \times 800 \text{ mm} + 40 \text{ mm}$
 e.g. three machines $3 \times 800 \text{ mm} + 40 \text{ mm} = 2440 \text{ mm}$
 Please check the opening requirements by the supplier.

Industrial, Catering and Medical washing equipment

72 -74 Woodlands Drive, Braeside, Victoria, 3195
PO Box 605 Braeside BC 3195

Tel: + 61 3 8586 5444

Fax: + 61 3 8586 5454

info@rhima.com.au

www.rhima.com.au

Rhima Australia Pty Ltd

ABN: 63 007 242 604

